

REVERSE T







WALL HOOD 90



CODE ID

FTHD 900 TC BK X



-  Auto - Power Off
-  Energy Class
-  Suction
-  Timer
-  Filtering
-  LED Lighting
-  Wall - Hung Installation

WALL HOOD

Energy Class: A

PERFORMANCE

Suction power up to 730 m³ / h

4 suction levels

Auto-off

Filter saturation indicator

Suction operation with

filter predisposition

Sound power from 47 to 72 dBA

FEATURES

Touch controls

LED bar lighting with side
and front bars

PRO-Baffle professional filter in stainless steel

Minimum air outlet Ø 150 mm

SERIES ACCESSORIES

Power Cord

OPTIONAL ACCESSORIES

FCHF 28: carbon filter for filtering version



STAINLESS STEEL - BLACK GLASS

FTHD 900 TC BK X

FULGOR MILANO

VENTILATION

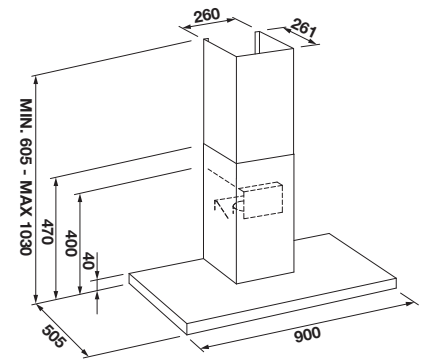

FTHD 900 TC BK X	
Type	Electronic
Finishing	Stainless steel with black glass insert
Installation	Wall
FEATURES	
Energy efficiency class	A
Speed levels	4
Automatic cut-off	• 10 minutes
Grease filter reset warning light	•
Charcoal filter reset warning light	•
Lighting type	LED bar (front - side)
Grease filters material	Professional baffle in stainless steel
Dishwashable grease filters	•
Ø duct diameter	Ø 150 mm
Non return flap	•
CONTROLS	
Programming non return flap	Touch control
Remote control	•
POWER RATINGS	
Output m ³ /h (max)	730
Sound level (dBA)	47 - 72
Yearly energy consumption (kWh)	49
Motor power (W)	275
Tension and frequency (V-Hz)	230 - 50
Power cord length (m.)	2
ACCESSORIES	
Motor	•
HP filter for filtering version	FCHF 28
DIMENSIONS	
Width mm	900
Height mm	605 - 1030
Depth mm	505